

DECKHAND® DH5HP

The HP stands for high performance. Engineered and built to accomplish the toughest jobs including vertical applications, the DECKHAND® DH5HP is revolutionizing the way contractors handle utility poles, pipe and casings.

- Head unit mounts to any brand of excavator in the 20-36 metric ton class
- Maximizes maneuverability with 360° continuous rotation, ability to shift loads 5.5 inches in either direction with integrated shift function, and tilt loads up to 24.5°.
- Load locking valves hold load securely, regardless of hydraulic pressure
- In-cab display allows operator to safely monitor and adjust all functions, working parameters, and hydraulic settings from inside the excavator.
- Requires auxiliary hydraulic circuit on excavator and dedicated case drain line
- Designed to meet ASME Below-The-Hook Lifting Standards
- Optional stick-mounted camera allows operator to see in even the most difficult spaces.

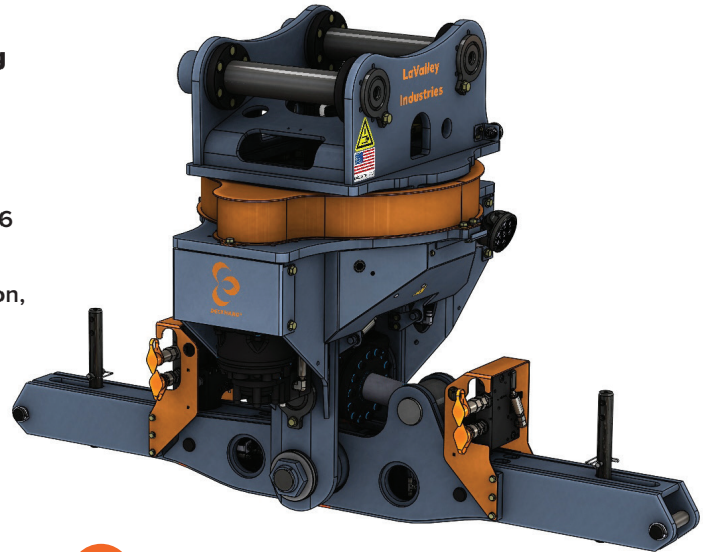

DECKHAND® DH5HP HEAD UNIT

Part Number	5249
Model Number	DH5HP
Excavator Wt Class	20-36 METRIC TON
Supply Pressure	5000 PSI / 345 BAR
Max Flow	30 GPM / 114 LPM
Min Flow	20 GPM / 76 LPM
Standard Recommended Flow	25 GPM / 95 LPM
Main Beam Size	6x6
Capacity	30,000 LB / 13,608 KG
Weight	3246 LB / 1472 KG
Dimensions	86L x 51W x 53H (IN) / 218L x 130W x 135H (CM)



www.lavalleyindustries.com

▲ DECKHAND® DH6HP

The HP stands for high performance. Engineered and built to accomplish the toughest jobs including vertical applications, the DECKHAND® DH6HP is revolutionizing the way contractors handle utility poles, pipe and casings.

- Head unit mounts to any brand of excavator in the 20-36 metric ton class
- Maximizes maneuverability with 360° continuous rotation, ability to shift loads 5.5 inches in either direction with integrated shift function, and tilt loads up to 24.5°.
- Load locking valves hold load securely, regardless of hydraulic pressure
- In-cab display allows operator to safely monitor and adjust all functions, working parameters, and hydraulic settings from inside the excavator.
- Requires auxiliary hydraulic circuit on excavator and dedicated case drain line
- Designed to meet ASME Below-The-Hook Lifting Standards
- Optional stick-mounted camera allows operator to see in even the most difficult spaces.

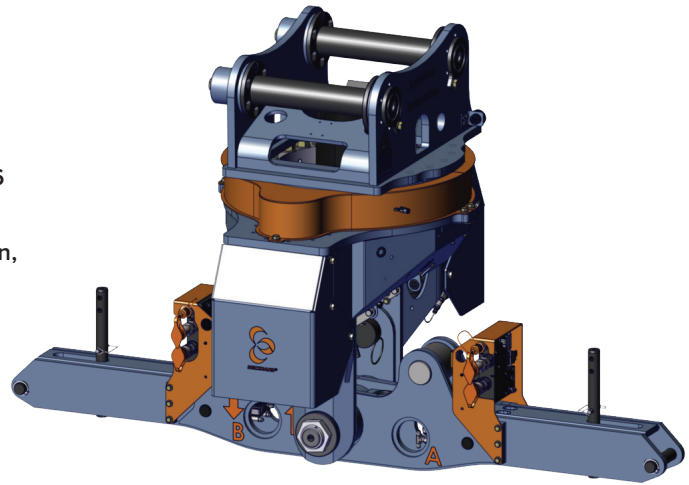

DECKHAND® DH6HP HEAD UNIT

Part Number	11000
Model Number	DH6HP
Excavator Wt Class	20-36 METRIC TON
Supply Pressure	5000 PSI / 345 BAR
Max Flow	30 GPM / 114 LPM
Min Flow	20 GPM / 76 LPM
Standard Recommended Flow	25 GPM / 95 LPM
Main Beam Size	6x6
Capacity	30,000 LB / 13,608 KG
Weight	3246 LB / 1472 KG
Dimensions	86L x 51W x 53H (IN) / 218L x 130W x 135H (CM)



www.lavalleyindustries.com