

**VOLVO ECR58F
WITH TWINDRIVE**

- DIESEL DRIVE AND EMISSION-FREE ELECTRIC DRIVE
- DIESEL ENGINE 35 KW – TIER 4F (STAGE V)
- ELECTRIC MOTOR 30 KW (400 V/50 HZ)
- ELECTRICAL CONNECTING LOAD 56 A
- OPERATING WEIGHT 6.6 T
- CABLE REEL 25 M



TwinDrive drive, a combination of conventional diesel drive and an additional emission-free electric drive. Both drive systems are each equipped with a separate hydraulic pump that feeds into the standard hydraulic system via a shuttle valve system. This ensures full, unrestricted operation of the machine in both operating modes. Operation of the heating and air conditioning system is guaranteed in both drive modes

SSM, with its 45 years of experience, equips a selection of Volvo excavators with cable-connected electric drive for emission-free continuous operation on site. Some models are also available with TwinDrive (diesel and electric motor) for maximum flexibility in use - always as Volvo machines, with manufacturer's warranty and CE certification.

DRIVE SYSTEMS

Twin-Drive system consisting of:

Diesel drive unit with liquid-cooled 4-cylinder Volvo D2.6H turbo diesel engine, equipped with oxidation catalytic converter and diesel particulate filter. Complies with Tier 4f (Stage V) emissions regulations

| | | |
|---|-----|-----|
| Max. power (at 2200 rpm) | kW | 35 |
| Variable displacement axial piston pump with load sense control | | |
| Max. pump flow rate (at 2200 rpm) | l | 143 |
| Max. hydraulic operating pressure | bar | 260 |

Electric drive unit with air-cooled asynchronous electric motor

| | | |
|---|-----|-----|
| Rated power (400 V / 50 Hz) | kW | 30 |
| Variable displacement axial piston pump with load sense control | | |
| Max. pump flow rate (at 1470 rpm) | l | 143 |
| Max. hydraulic operating pressure | bar | 260 |

Hydraulic System

| | | |
|--|-------|-----|
| Maximum system flow (both drives, D & E) | l/min | 143 |
| Maximum operating pressure (main pumps) | MPa | 26 |
| Maximum flow for accessories | l/min | 75 |
| Maximum pressure for accessories | MPa | 22 |
| Maximum flow for 2nd accessory circuit | l/min | 40 |

ELECTRICAL SYSTEM

The TwinDrive retains the standard Volvo machine electrics. For the electric drive an additional electrical switchgear is installed, which is connected to the normal on-board electrical system.

A spring winding cable reel is installed on the cab roof to supply the electric drive with power and the upper-carriage is equipped with a swivelling angle limiter (prevents the power supply cable from becoming entangled when swivelling). The I-ECU display unit and the electric drive panel are located next to the driver's seat and control and monitor the machine functions.

| | | |
|------------------------------------|--------|----------|
| On-board electrical system | V | 12 |
| Battery | V / Ah | 12 / 74 |
| Alternator | V / Ah | 12 / 70 |
| Electrical system e-drive | V / Hz | 400 / 50 |
| Cable reel capacity | m | 25 |
| Reeling cable | Typ | 4G16 |
| Electrical connecting load | A | 56 |
| Electrical connection via CCE plug | A | 63 |

UNDER CARRIAGE WITH TRAVEL SYSTEM

Robust X-shaped frame with permanently greased and sealed track chains as standard. Dozer blade on the undercarriage.

Each track is powered by an automatic two-speed shift travel motor. The track brakes are multi-disc, spring-applied and hydraulic released.

| | | |
|--|------|--------------|
| Crawler tracks with triple grouser shoes | | |
| Width of steel grouser shoe | mm | 380 |
| Width rubber plated grouser shoe | mm | 400 |
| Max. drawbar pull | N | 4.748 |
| Max. travel speed, switchable (low / high) | km/h | 2,6 (D & E) |
| | | 4,5 (only D) |

SWING SYSTEM

Maintenance free hydrostatic swing system, with radial piston motor and an automatic holding brake and anti-rebound valve are standard

| | | |
|------------------|------|-------|
| Max. slew speed | rpm | 8,7 |
| Max. slew torque | daNm | 1.229 |

CABIN

Enclosed cab with ROPS (roll-over protection) and FOPS level 1 (protective structure against falling objects) as well as TOPS (protection against risk of injury).

Sprung driver's cab, height-adjustable seat, consoles and joysticks; all spring-mounted as a unit, high-contrast LCD display with day/night mode for readability in any light, displays for fuel level and coolant temperature, engine speed, flow rates for additional functions and boom offset, symbols and graphics for engine and operating mode, colour-coded messages and help menu, operating hours counter, automatic engine stop switch for emergencies, prevents failures in the event of coolant overheating or low engine oil pressure, warning lights if the hydraulic and air filters are clogged, several warning lights coupled with acoustic signals if a fault occurs (overheating malfunction occurs (overheating, oil pressure drop, low battery voltage).

BOOM EQUIPMENT

Welded mono-bloc boom, protection of the boom cylinder piston rod, Swivelling frame inside the undercarriage: boom extension cylinder under integrated lifting point on the boom, tightly welded monobloc stick, high-quality, durable bearing bushes, tempered, pre-lubricated and corrosion-resistant pins, offset lubrication point of the stick cylinder point of the stick cylinder accessible from the ground.

DIGGING PERFORMANCE

| | | |
|---|-----|-------|
| Standard bucket width | mm | 600 |
| Tear-out force, bucket (ISO) | daN | 4.194 |
| Ripping force acc. ISO with short arm (1650 mm) | daN | 2.841 |
| Ripping force acc. ISO with long arm (1950 mm) | daN | 2.518 |

SERVICE REFILL

| | | |
|------------------------|---|---------|
| Fuel tank | l | 70 |
| Hydraulic system total | l | 76 |
| Hydraulic oil tank | l | 47 |
| Diesel engine oil | l | 10,2 |
| Diesel engine coolant | l | 9 |
| Travel reduction gear | l | 2 x 0,8 |

SOUND LEVEL

| | | |
|--|----|----|
| Sound pressure level in cab according to ISO 6396 | | |
| LpA (standard) | dB | 74 |
| External sound level according to ISO 6395 and EU Noise Directive 2000/14/EC | | |
| L _{wa} (standard) | dB | 97 |

Further details upon request.

Subject to changes.

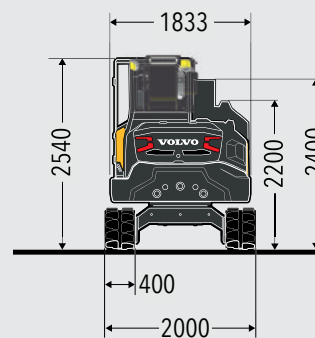
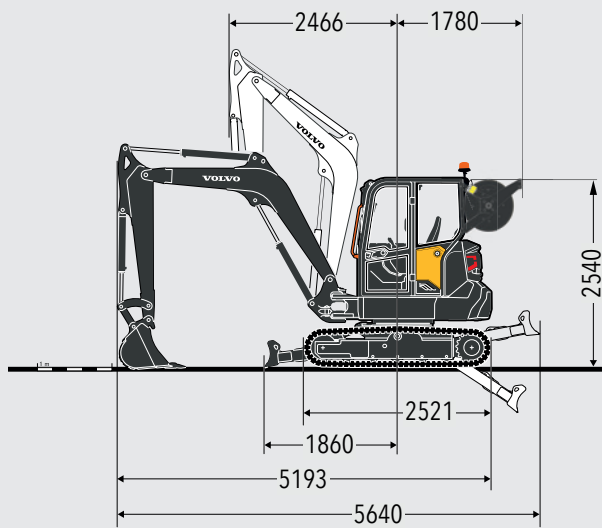
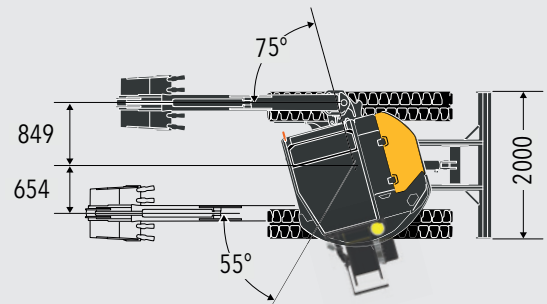
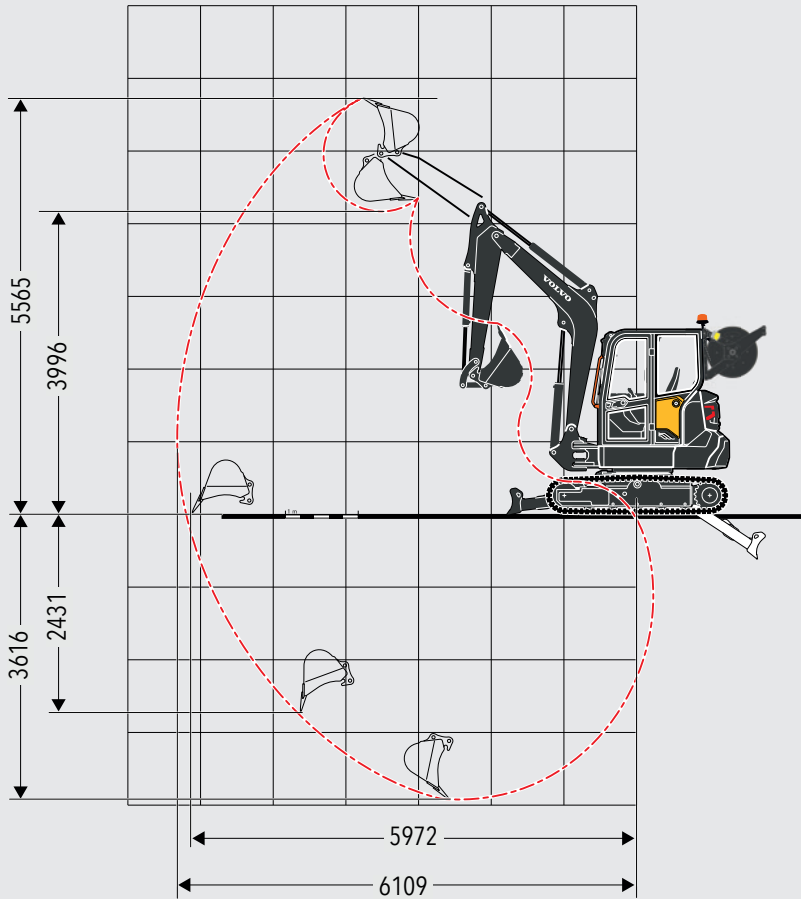

The data refers to the boom with short arm (1650 mm), also available with long arm (1950 mm).

All dimensions in mm.



Schöller special machines GmbH & Co.KG
 Bachstraße 19
 D-74585 Rot am See – Hausen am Bach
 T: +49 7958 999969-0
 Service Hotline: +49 152 26235138
 E-Mail: info@itc-ssm.de
 www.itc-ssm.de